

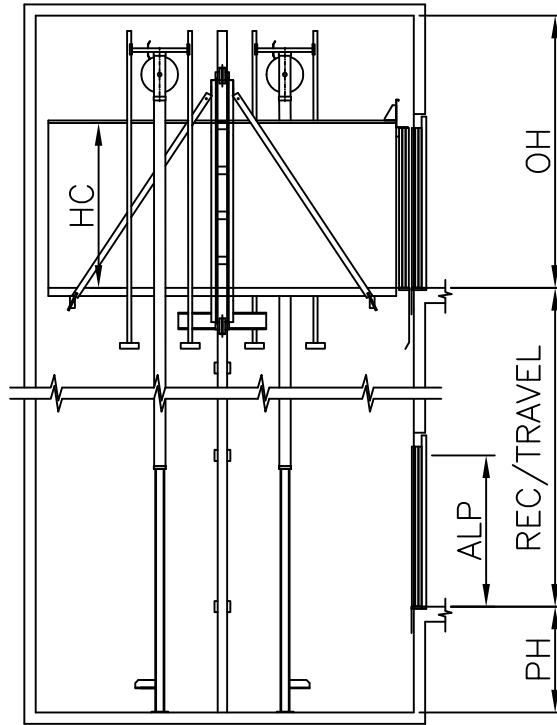

ESCALA / SCALE 1:100

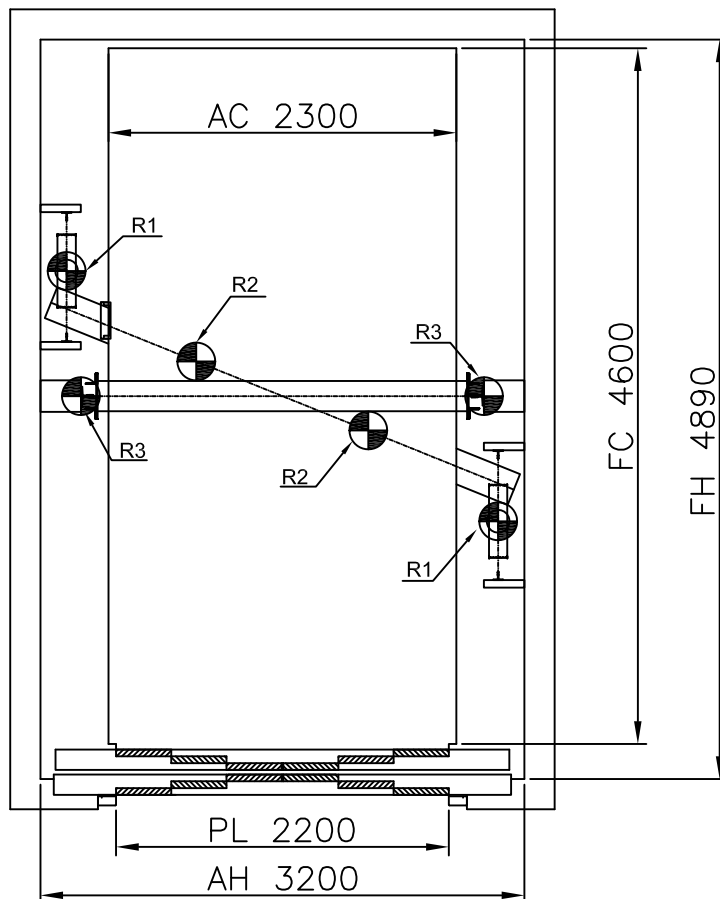

ESCALA / SCALE 1:50



MP 30CO 02H 2:1		3000 Kg		
ACCIONES SOBRE EL HUECO / SHAFT REACTIONS		40P.		
R1	CARGA EN PISTÓN / JACK LOAD	94750 N	0.2 m/s	
R2	CARGA EN PUFFER / BUFFER LOAD	120000 N	FOSO / PIT	
R3	CARGA EN GUÍA / GUIDE LOAD	93000 N	HUIDA / OVERHEAD	
	REACCION DE GUIAS Sx / GUIDES REACTIONS Sx	7400 N	1400	3600
	REACCION DE GUIAS Sy / GUIDES REACTIONS Sy	8000 N		
				24 Kw

ESCALA / SCALE 1:100

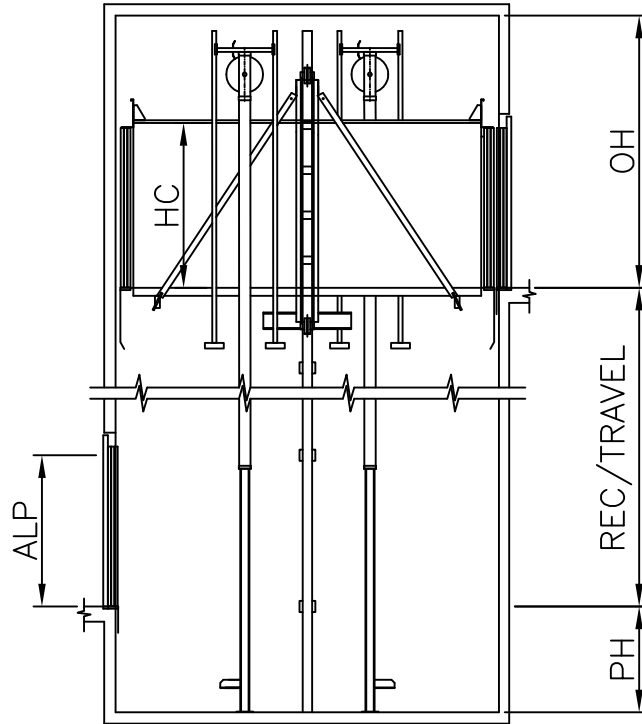

ESCALA / SCALE 1:50

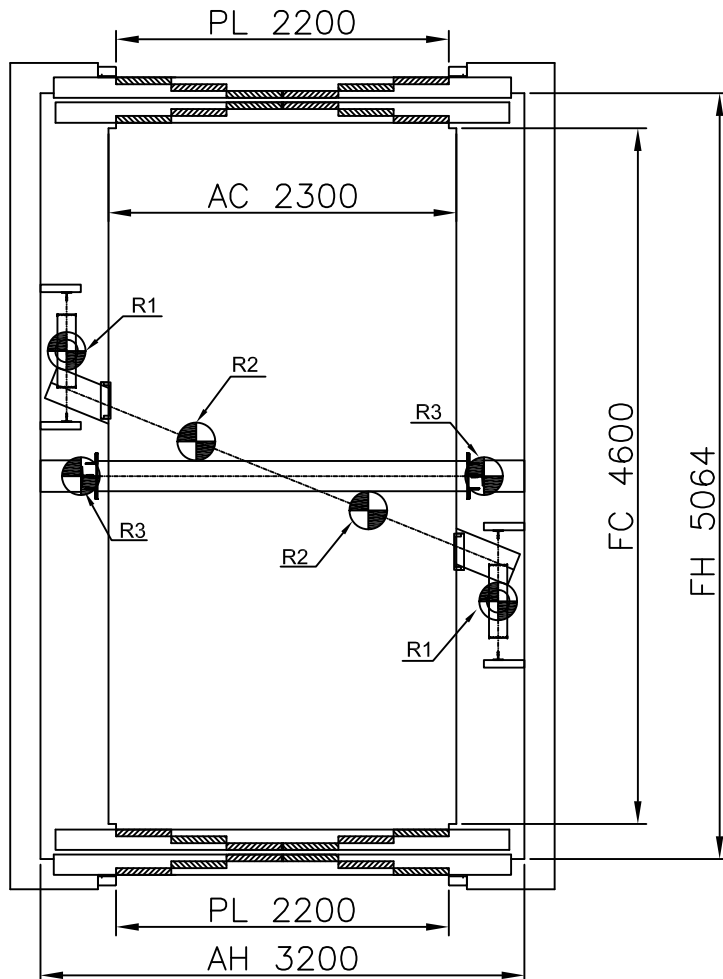

MP 30CO 02H 2:1 D.E.180°

3000 Kg

ACCIONES SOBRE EL HUECO / SHAFT REACTIONS

40P.

0.2 m/s



R1	CARGA EN PISTÓN / JACK LOAD	94750 N
R2	CARGA EN PUFFER / BUFFER LOAD	120000 N
R3	CARGA EN GUÍA / GUIDE LOAD	93000 N
	REACCION DE GUIAS Sx / GUIDES REACTIONS Sx	7400 N
	REACCION DE GUIAS Sy / GUIDES REACTIONS Sy	8000 N

FOSO / PIT HUIDA / OVERHEAD

1400

3600

24 Kw

ESCALA / SCALE 1:80

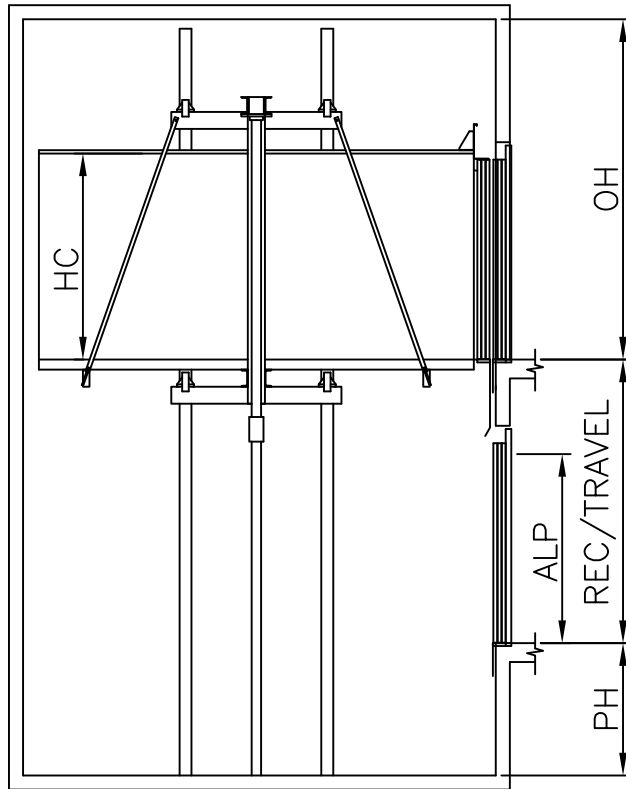

ESCALA / SCALE 1:50

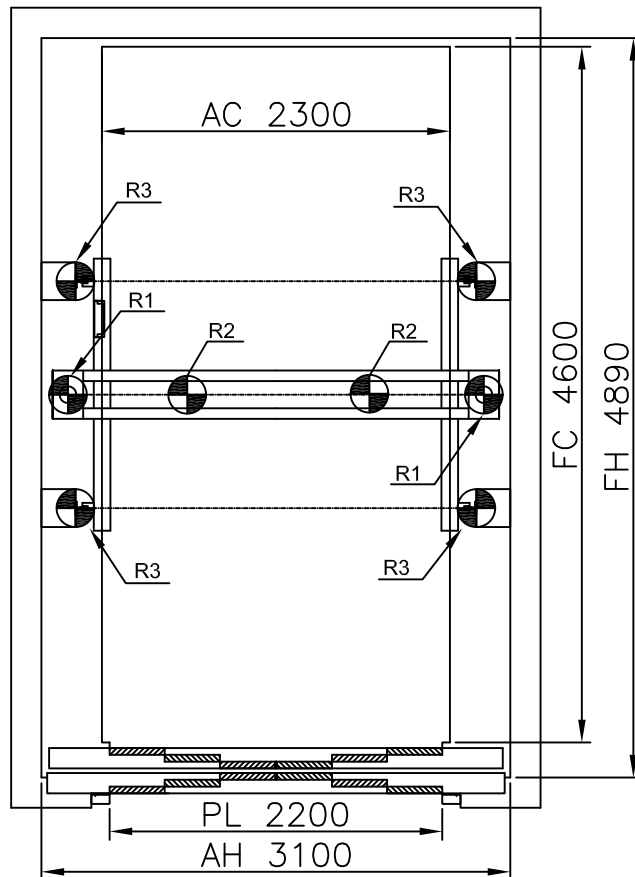

MP 30CO 02H 1:1

3000 Kg

ACCIONES SOBRE EL HUECO / SHAFT REACTIONS

40P.

R1	CARGA EN PISTÓN / JACK LOAD	60000 N
R2	CARGA EN PUFFER / BUFFER LOAD	120000 N
R3	CARGA EN GUÍA / GUIDE LOAD	63250 N
	REACCION DE GUIAS Sx / GUIDES REACTIONS Sx	5150 N
	REACCION DE GUIAS Sy / GUIDES REACTIONS Sy	5150 N

0.2 m/s

FOSO / PIT HUIDA / OVERHEAD

1400

3600



20 Kw

ESCALA / SCALE 1:80

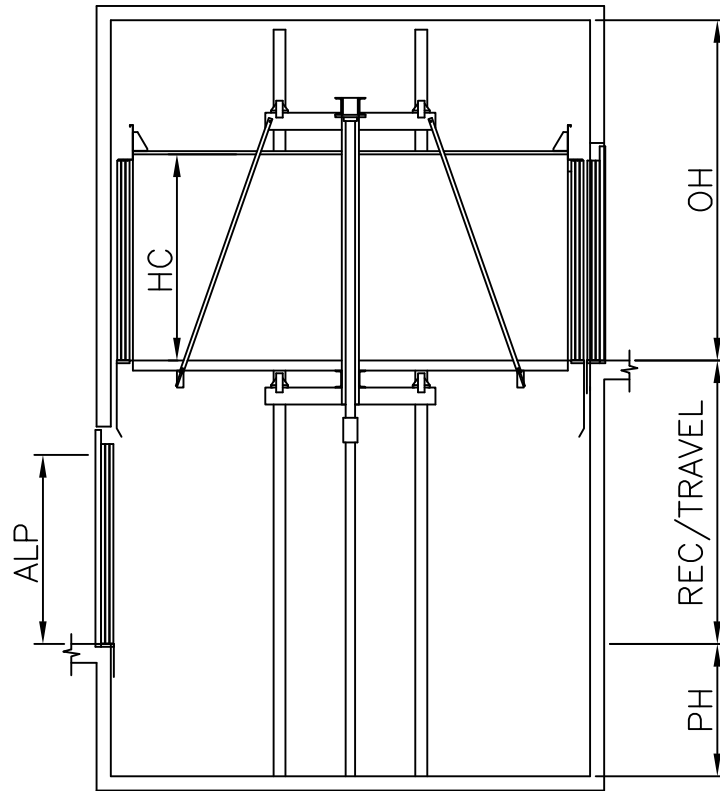

ESCALA / SCALE 1:50

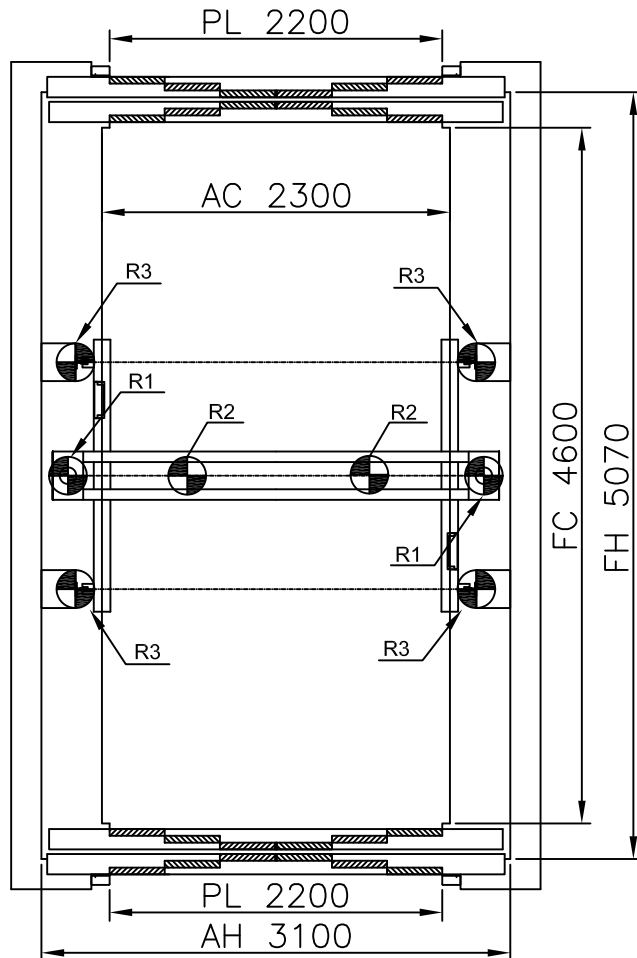

MP 30CO 02H 1:1 D.E.180°

3000 Kg

ACCIONES SOBRE EL HUECO / SHAFT REACTIONS

40P.

0.2 m/s

R1	CARGA EN PISTÓN / JACK LOAD	60000 N
R2	CARGA EN PUFFER / BUFFER LOAD	120000 N
R3	CARGA EN GUÍA / GUIDE LOAD	63250 N
	REACCION DE GUIAS Sx / GUIDES REACTIONS Sx	5150 N
	REACCION DE GUIAS Sy / GUIDES REACTIONS Sy	5150 N

FOSO / PIT

HUIDA / OVERHEAD

1400

3600



20 Kw