

ESCALA / SCALE 1:80

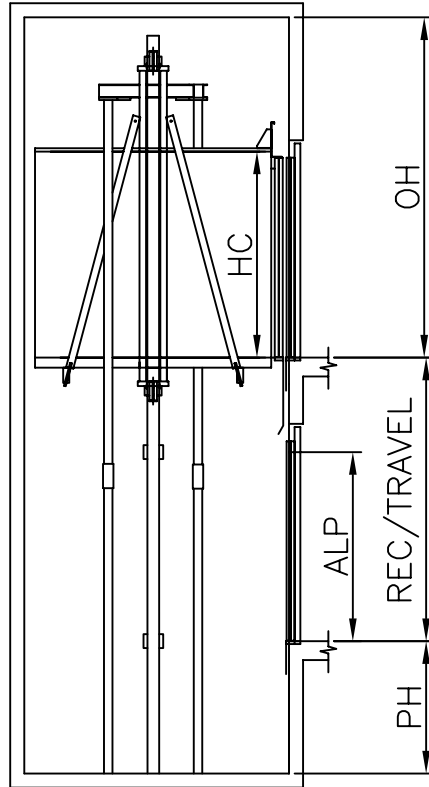

ESCALA / SCALE 1:40

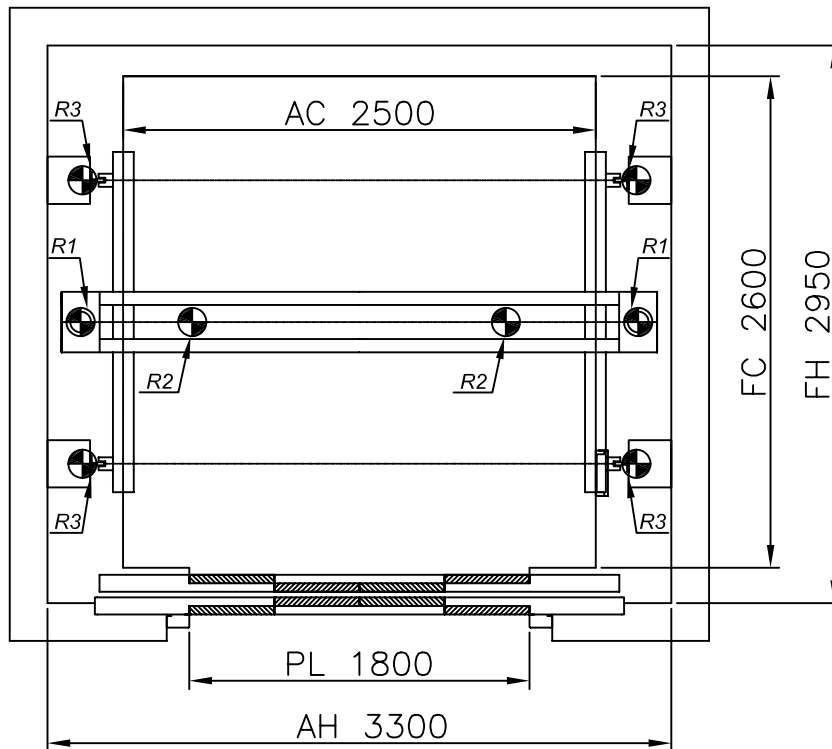

MP 4605 H "C" 1:1

3500 Kg

ACCIONES SOBRE EL HUECO / SHAFT REACTIONS

46P.

R1	CARGA EN PISTÓN / JACK LOAD	40200 N
R2	CARGA EN PUFFER / BUFFER LOAD	108800 N
R3	CARGA EN GUÍA / GUIDE LOAD	55825 N
	REACCION DE GUIAS Sx / GUIDES REACTIONS Sx	5025 N
	REACCION DE GUIAS Sy / GUIDES REACTIONS Sy	6475 N

0.5 m/s

FOSO / PIT HUIDA / OVERHEAD

1400

3600



44 Kw

ESCALA / SCALE 1:80

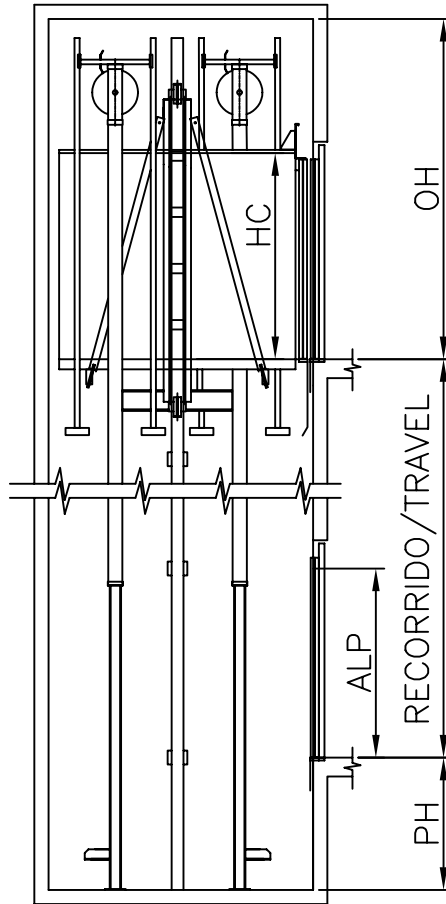

ESCALA / SCALE 1:40

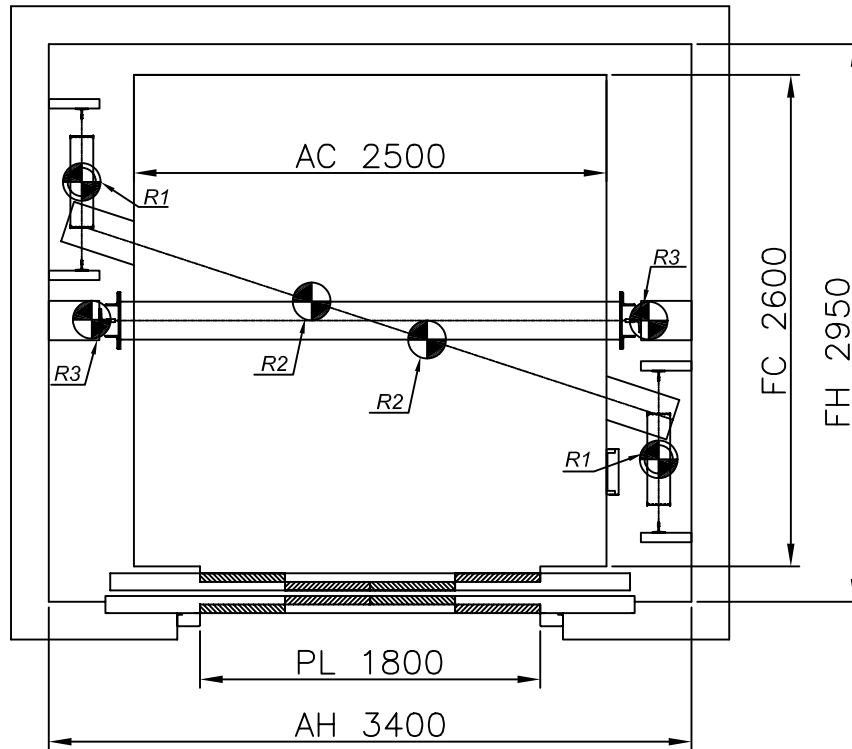

MP 4605 H "C" 2:1

3500 Kg

ACCIONES SOBRE EL HUECO / SHAFT REACTIONS

46P.

R1	CARGA EN PISTÓN / JACK LOAD	86050 N
R2	CARGA EN PUFFER / BUFFER LOAD	108800 N
R3	CARGA EN GUÍA / GUIDE LOAD	84800 N
	REACCION DE GUIAS Sx / GUIDES REACTIONS Sx	7525 N
	REACCION DE GUIAS Sy / GUIDES REACTIONS Sy	9725 N

0.5 m/s

FOSO / PIT HUIDA / OVERHEAD

1400

3600



51.5 Kw